

Wearable Device to Keep Track of Respiratory Tract Diseases for Future Diagnosis Using History

N. Mullai Rajan^{1,*}, J. Meenu², S.V. Subadevi³, S. Sathish⁴, Vishwajith R.⁵

Abstract

We are living in a generation in which the humans are exposed to an unhealthy environment and with unhealthy habits, resulting in respiratory issues. In most of the cases, it causes fatal diseases like Chronic Obstructive pulmonary disease (COPD) have no initial symptoms, when the disease is at its serious stage the symptoms can be realized due to this character proper treatments cannot be given to the victim at the proper time. In most fatal cases, the victims were dead only due to the improper treatment; this is because the history of the smoking frequency and exposure of the victim to the polluted environment is unknown by the doctor. For the proper treatment of the patient, the histories like coughing, smoking, breath frequencies could help. Environmental parameters like atmospheric pressure, chemicals such as diesel fumes, may lead to the respiratory issues. Even before the treatment process, the victim could change the environmental exposure and smoking habits so that the serious condition can be avoided. Considering these facts, we came up with a device that could monitor the harmful gases and environmental pressure the patient is exposed to; and importantly, the breathing rate of the patient can be monitored. Their smoking habit rate and coughing rate can be used as the historical data for future treatment and for changing the habits and workplace environment.

Keywords: Unhealthy environment, respiratory issues, COPD, historical data

INTRODUCTION

Respiratory illness is common in the world we live in; the reason behind this fact could be many factors like the workplace or environmental exposure and the patients' habits. Reversible lung disease like asthma has major proportionality with environmental allergies; in some cases, this could be due to the infectious and polluted environment. The typical phenomenon of the asthma patient would be symptoms and the treatments from their age of adulthood or in old age but the victims must be having traces and minor symptoms of the presence of the asthma in their childhood which they were never aware of. Chronic Obstructive Pulmonary Disease affects more than 200 million people in the world, 65 million of whom have moderate or severe airway disease, and most studies show that it is under-

diagnosed by 72 to 93%. This is higher than reported for hypertension, hypercholesterolemia, and many other important disorders. A major population of lung patients is in Chronic Obstructive Pulmonary Disease since it encompasses several diseases. Most likely, this disease's symptoms are confused with the aging issues, but the gradual aging issues and the chronic obstructive pulmonary disease have insignificant variation. In concept, COPD can develop over several years with shortness of breath. This begins in their 30s and peaks in the 60s. According to the American Lung Association, COPD is the third leading cause of death in the US. More to this,

*Author for Correspondence

N. Mullai Rajan
E-mail: mullairajan2000@gmail.com

Students, Department of Electrical and Electronics Engineering, SNS College of Technology, Vazhiyampalayam, Coimbatore, Tamil Nadu, India

Received Date: May 11, 2021
Accepted Date: September 15, 2021
Published Date: October 20, 2021

Citation: N. Mullai Rajan, J. Meenu, S.V. Subadevi, S. Sathish, Vishwajith R. Wearable Device to Keep Track of Respiratory Tract Diseases for Future Diagnosis Using History. Journal of Artificial Intelligence Research & Advances. 2021; 8(2): 51-58p.

respiratory diseases like chronic bronchitis, emphysema, lung cancer, cystic fibrosis/bronchiectasis, pneumonia, pleural effusion, and even COVID-19 have common minor symptoms at its initial period of the infection, like shortness of breath, frequent cough etc. According to the Centers for Disease Control and Prevention (CDC), most of the disease can be treated in the initial stage; considering this fact, we designed a device that will monitor some important factors for the treatment [1].

STUDYING PROBLEM STATEMENT

Inappropriate Treatment

Though most of the diseases can be cured with proper and appropriate treatment; according to the experts, the COPD cannot be cured, and the treatment will help for reducing the symptoms by easing the patient and increase the quality of life. Even in the case of treating the patients, it requires proper historical data about the patient. Due to the lagging of the historical data of the patient, most of the doctors will prescribe a possible solution to their knowledge [2].

Symptoms in the Initial Stage

Diseases like asthma have no initial stage symptoms. According to studies, asthma is due to exposure to infectious environment and smoking weed; since in the 30s, the victim wasn't feel any kind of discomfort, so they continue their exposure and smoking habit, later in 50s or 60s, when the disease will be in its serious condition then they will realize the symptoms of the disease [3].

SYSTEM OVERVIEW

In RDA (Respiratory Data Analyst)-Forecaster, the system comprises of detection unit in which required parameters are detected and in the processing unit, the detected parameters will be converted into Canvas drawing file format for future access in case of treatment.

Detection Unit

Infectious Environmental Exposure

Many people are surrounded by harmful gases such as carbon monoxide which are produced by partially burned fossil fuels like wood fuels, coal, charcoal, gas. Ammonia and other flammable gases severely irritate the respiratory tract. By being exposed to these gases, our respiratory system collapses and numerous lung diseases can be caused whose symptoms cannot be detected immediately but by later [4]. To conclude these issues, we are introducing various 'MQ sensors' to detect the polluted air'. 'MQ-4' sensor is used to detect methane and CNG (Compressed Natural Gas) which are emitted by squeezing the natural gas, likewise 'MQ-9' sensor detects the carbon monoxide and other flammable gases in the atmosphere, lastly, we used 'MQ-135' sensor to mainly ensure the purity of air by detecting carbon monoxide(CO), ammonia, smoke.

Radon Exposure

Radon is a colorless, odorless, tasteless noble gas that is primarily formed by decaying radioactive elements such as uranium or radium. The most dangerous consequence of radon gas is that it is potentially available everywhere because it is naturally occurring radioactive gas and it cannot be sensed by human vision. Radon gas takes a major role in causing lung cancer other than cigarette smoking [5]. Radon exposure may also lead to a decrease in muscle mass. Even a non-cigarette smoker can be affected by lung cancer due to this radon gas exposure. This vigorous radioactive gas can be detected by using the Geiger counter. Typically, this is used to detect the radioactive substance present in an area, when the radiations pass through the counter tube, the gas molecules inside the tube get excited which produce an electrical current proportional to the radioactive concentration and it can be interfaced with raspberry pi through USB cable.

Smoking Weed

Unceasing exposure to cigarette smoking may lead to various respiratory diseases such as COPD, lung cancer, chronic bronchitis etc. The major component of cigarette smoke is contributed by carbon

monoxide (CO), the redox potential of smoke, certain N-nitrosamines but we have taken carbon monoxide as a major composition; and by using 'MQ-9 Sensor', the concentration of carbon monoxide can be detected and how often the person smokes can also be stored by appropriate coding in R Pi.

Breathing Pattern

Shortening of Breath is one common symptom for most of the Respiratory illness, for recording the breathing pattern of the patient spirometer is used for measuring the breathing pattern. Since recording breathing patterns is the most important thing in the data analysis, it is important to have this data in the RDA. The spirometer cannot be the best choice for recording using RDA, So, Diaphragm of the Stethoscope is Connected to the Raspberry pi for monitoring the breathing pattern of the User.

Cough

Symptoms like coughing are a default symptom of respiratory illness; the user's coughing frequency pattern could be helpful in case of treating in a later period.

Salt-Tasting Skin

A wearable sweat sensor detects the hypotonic fluid in the epidermis layer of human skin, by using a non-enzymatic poly (3-APBA)-based lactate sensor. The sensor tracks the movement of sweat through the microfluidic and detects the concentration of electrolytes like potassium and sodium. The increase in human sweat rate stipulates genetic disorder of cystic fibrosis in the lungs and digestive system. This wireless flexible sensor transmits the data through the Zigbee module through Bluetooth.

Atmospheric Pressure

The barometer BMP180 sensor senses the low and high air pressure. When the altitudes are in low air pressure, it makes the person harder to breathe. This sensor acts as a transducer which is made of stainless steel, silicon, etc. and converts one form of energy into another form.

Recording Specification

The coughing and smoking exposure will be in wave and json file format respectively as the input to the microcomputer; the instances are taken as the count-based data for better data recording and it is saved in the csv file format. For the betterment of the historical data collection, it will be stored by days. Infectious gas exposure such as ammonia, Compressed Natural Gas and flammable gas will be detected using MQ sensors, json file formatted input will be recorded along with a range of exposure and the count in csv file format. Same as that the gas exposure records the atmospheric pressure, diesel fumes and radon exposure, will be recorded along with range in csv file. Exceptionally, the breath length will be saved for the time taken as in the csv file, and plotted form of the output of the breathing rate can be displayed by inheriting the data from the csv file format. The data about the breathing rate for years could give better information about the disease in the prior stage.

FABRICATION AND PROCESSING UNIT

In RDA, the central processor is Raspberry Pi which is powerful enough to be used for simultaneous data collection, cleaning, amplification, and recording; there is no user interface enabled in this device since the parameters detected are technical data. The data can be taken from the system as a csv file format for analysis.

Interfacing Diaphragm with R Pi

The diaphragm (Chest-piece) of the stethoscope is connected to R Pi using single channel microphone; the recording file will be kept on dump into the R Pi; to eliminate the electronic sound, many sound engineering steps are carried out for getting a fine result of analysis as follows:

Noise Removal

We used 'wav' and 'adipoop' for reading and processing the wave file which was streaming into the device. The sound inputs were taken in the frequency domain using the FFT function provided by python. All the frequencies streamed in the device other than desired frequencies were removed. To

remove electronic noise produced by the microphone, sounds of frequencies outside the desired range of frequency were captured along with electronic noise and excluded from the heartbeat recordings, thus providing us with clean lung sound, as shown in Figure 1. Apart from the electronic and surrounding noises, murmurs (Noises from the heart) were also be excluded for intensifying the detection of the lung sound.

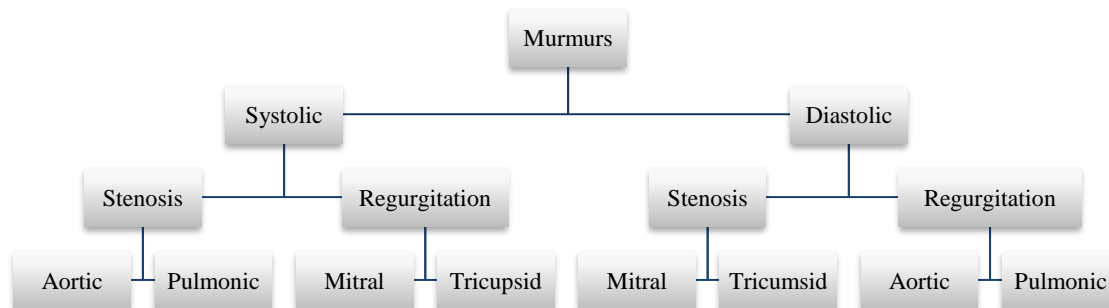

Figure 1. Noises from the Heart when the Blood flows the chamber to chamber.

Stream Amplification

The noise detected source file is amplified 20 to 40 times as per the requirement of the medical practitioner. To do that, we multiplied the time domain data to the amplification factor directly.

Sound Plotting

At the instance, after removing noise id and amplification, the streaming is plotted using 'matplotlib' and 'scipy' libraries of python.

Interfacing Microphone

Wave files of the coughing sample from the source like RALE or other sources will be dumped into the microcomputer; so, the microphone which is connected to the microcomputer could differentiate the noise and the coughing sound. Coughing sound of another party, who is apart from the user, can be excluded using the data of the lung elongation of the user; if the microphone detects a coughing sound while the diaphragm did not detect the lung elongation, that coughing sound will not be taken into account. Instead of neglecting or deleting another party's coughing sound, it can be saved as the exposure of the user to the infectious foreign bodies as shown in Figures 2 and 3.

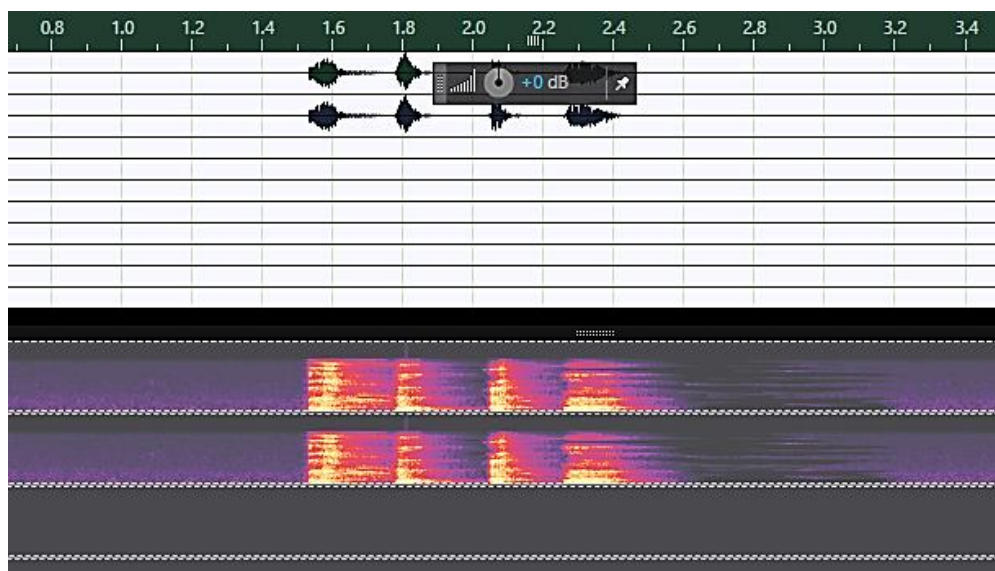

Figure 2. Wave Samples of User's Cough.

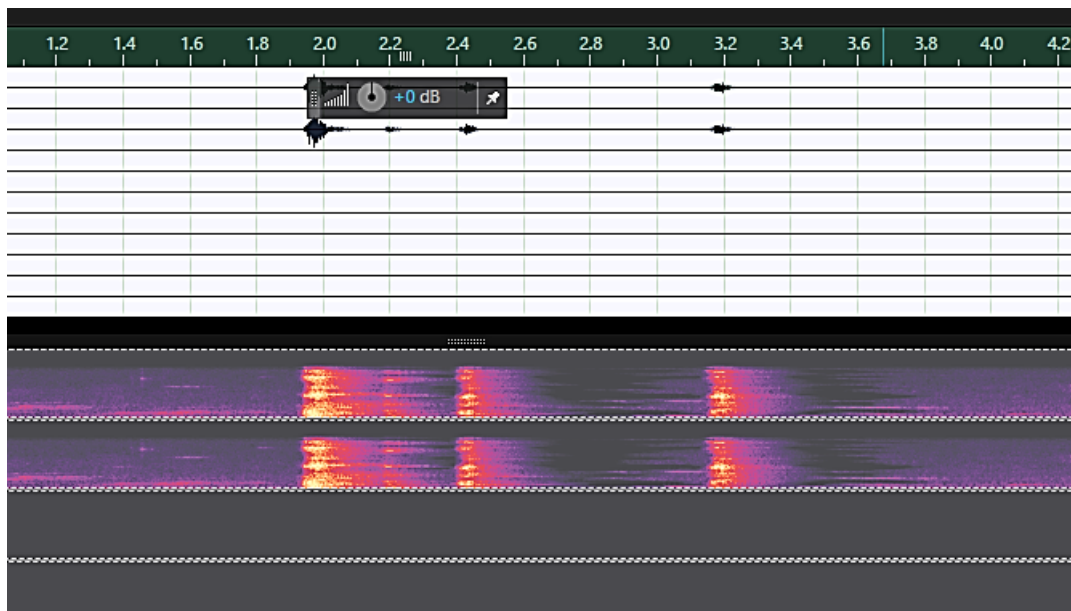

Figure 3. Wave Samples of Non-User's Cough.

Interfacing Geiger Counter

Geiger counter is interfaced with the raspberry pi by connecting the female port of the USB cable with appropriate software programs. This interfacing is possible only when raspberry pi is installed with FTDI drivers. When the connections are fabricated, random bits are induced corresponding with the random radiations exposed by the counter.

BLOCK DIAGRAM AND WORKING

For the process of the RDA system, ammonia, Compressed Natural Gas (CNG), and flammable gas exposed to air will be detected using MQ sensors. Further, colorimetric sweat sensor is a wireless flexible sensor that helps to measure the level of glucose in human sweat where a thin redox mediator layer of Prussian blue is deposited on the base of an electrode which acts as greater sensitivity and visualizes the data in the smartphone. The cough sample is collected in the form of wav file and dumped in R pi through the microphone which acts as the medium to the R Pi and to differentiate the electronic noises, the microphone is connected to the microcomputer where third party's cough is excluded using the data of lung elongation. The diaphragm plays a vital role in the system, in the shortness of breath, coughs, sweat, and abnormal lung activities. For the sake of accuracy, the parameters are detected along with the help of other neighbouring sensors. The shortness of breath is monitored using the diaphragm along with the atmospheric pressure since the pressure influences the breathing pattern. While detecting the cough, for differentiating the user's cough and non-user's cough, the system will detect using a diaphragm and the microphone which is implanted externally from the diaphragm. Exclusively, 3-APBA based latent sensor is implanted to detect the sweat; using the data from the diaphragm the sweats can be predicted. Only for detecting the wheezing and other sudden abnormalities will be detected using diaphragm alone using sounds from the lung. Selective MQ series sensors will be used to detect infectious environment exposure and even smoking, as shown in Figure 4.

SCHEMATIC SETUP

Raspberry Pi's 13B GND and 13B 3v3 are connected to the BUS GND and BUS POS respectively. BMP180's VCC, GND, SCL, and SDA terminals are connected to BUS POS, BUS GND, 3b3, 3b2. Containing MQ series sensors have a similar kind of circuit setup, GND terminal is connected to the BUS GND, GND, and A Out terminals are short-circuited using 1k and 470 Ω resistors. VCC terminals are used to get data from the sensors (Figure 5). The MCP3008 will add 8 channels of the 10-bit analog input to RDA. It uses SPI where only 4-pins are required. Universal serial bus

microphone for R Pi is implanted in the tube of the diaphragm and Geiger Muller counter uses the same port for connection. Exceptionally, the latent sensor uses Bluetooth for communication with the microcomputer. The power source of the system is 5 V–10000 mAh lithium-ion battery.

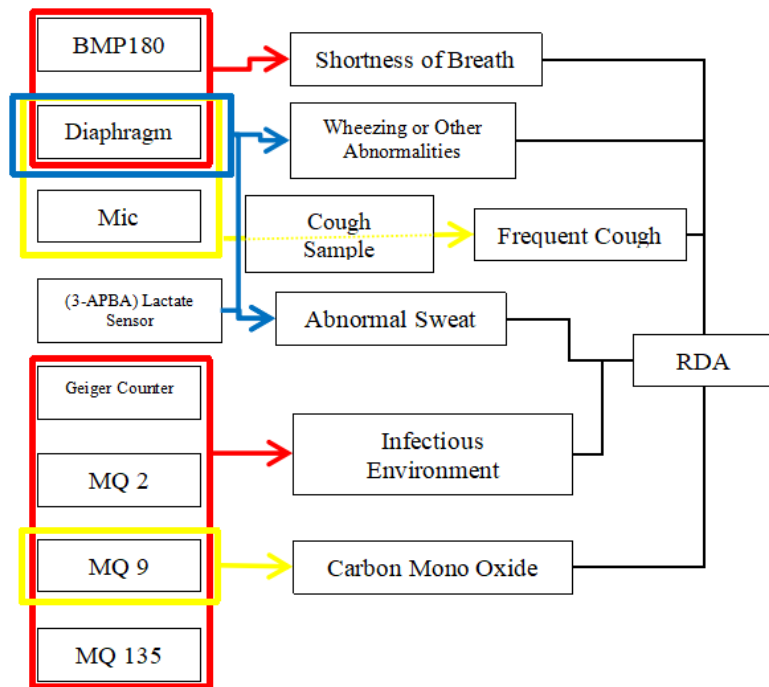

Figure 4. Block Diagram Representation for Working.

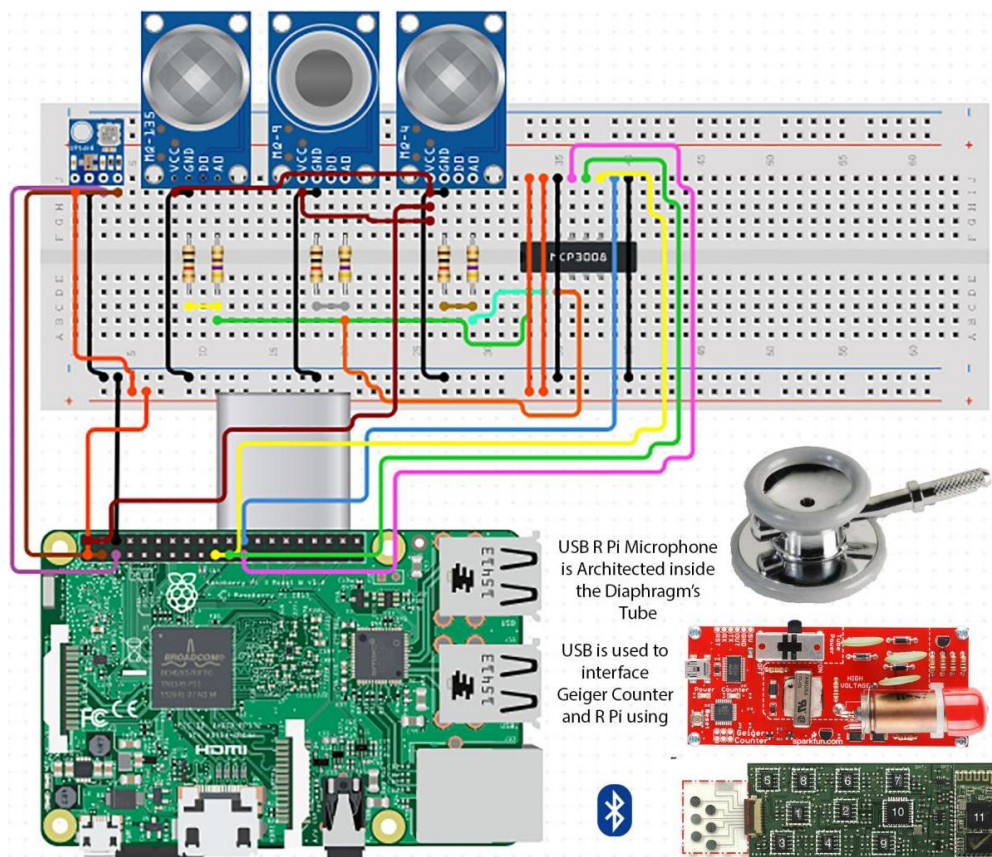

Figure 5. Simulated schematic setup.

IMPLEMENTATION

A leather or nylon material is used in the final product. A Velcro enabled belt could be easier for the user to use RDA consistently. Since the latent sensor is implanted wireless, that particular device is patched out from the belt, it can be patched either in the forehead or wrist Figure 6.



Figure 6. Simulated Design of the RDA Belt.

Financial Aspect

Given analysis define financial aspect of items in Table 1.

Table 1. Financial Aspect Analysis.

Items	Cost (\$)	Nature of Output	Power Consumption (mA)
MQ-135	3.95	Jason	150
MQ-9	1.85	Jason	150
MQ-4	1.78	Jason	150
Lactate sensor	12	Avi	24
BMP180	1.98	Csv	3000
R Pi Mic	18.52	Wav	500
Diaphragm	1.32	Wav	-
Geiger counter	300.53	Jpeg	300
R Pi	35	-	900-14000
Resistors ×6	-	-	-
Nylon wrapper	-	-	-

RESULT

Most of the respiratory diseases are complicated to predict; some may exist for short term while others for long term. The optimum cause of the RDA system is to break the hinderance accomplished by the respiratory complications whose symptoms cannot be signified formerly but later. RDA provides the necessary data regarding the person's breathing pattern, environmental exposure, smoking history etc. for better medications.

CONCLUSION

The immense health burden worldwide is imposed by respiratory diseases. The deaths caused by respiratory diseases account for about 10.2% of the total death rate in India. The first key for

respiratory health is preventing illness. Monitoring and public health care play an important role in preventing measures. RDA helps to promote the public health care sectors by monitoring the areas which are immensely affected by disease-causing factors.

LIMITATIONS

Diesel Fumes

Diesel fumes play a major role in lung cancer which has 97,000 active cases in India. But our system will not detect diesel fumes parameter since the working temperature of the sensor is too high which cannot be implanted nearer the human body.

Coughing of Blood

Coughing of blood is one of the common symptoms of the respiratory illness; in RDA, only the coughing frequency and gruffness can be detected, considering the fact the blood in the cough is only at the eventual stage, our system could alert before that stage.

Future Work

RDA excludes the heart murmurs to centralize the lung sound but in future work it can be included to diagnose the cardiovascular diseases by detecting irregular heartbeats. A server can be enabled to render a platform between the patient and the doctor, by which the doctor can track his/her consulting patients. If any heart diseases arise in the future, the doctor can directly monitor the patient and can recommend the necessary prescription.

Acknowledgment

We would like to acknowledge the help of Mr. N. Thillai Rajan, B.E., for Interfacing the Geiger counter into Raspberry Pi.

REFERENCES

1. Mullai Rajan N, Subadevi SV, *et al.* Car Event Data Recorder. *Journal of Emerging Technologies and Innovative Research (JETIR)*. 2020; 7(4): 562–568. ISSN and UGC Approved. ISSN: 2349-5162. <http://www.jetir.org/download1.php?file=JETIR2005183.pdf>
2. Mullai Rajan N, Subadevi SV. Application of Servo Motor: Strategy to Avoid the Wastage of Consumable Energy. *International Journal of Creativity Research Thoughts (IJCRT)*. 2020; 8(4): 3552–3556. ISSN: 2320-2882. http://www.ijcrt.org/viewfull.php?p_id=IJCRT2004489
3. Mullai Rajan N, Subadevi SV. Smart Environmental Monitoring System. *Journal of Emerging Technologies and Innovative Research (JETIR)*. 2020; 7(5): 290–296. ISSN and UGC Approved. ISSN: 2349-5162. <http://www.jetir.org/download1.php?file=JETIR2005183.pdf>
4. Chung M, Fortunato G, Radacsi N. Wearable flexible sweat sensors for healthcare monitoring: a review. *J R Soc Interface*. 2019; 16(159): 20190217. <http://dx.doi.org/10.1098/rsif.2019.0217>
5. Disease Conditions, India has most number of TB cases in the world. [Online]. Available: <http://health.india.com/diseases-conditions/india-has-the-most-number-of-tuberculosis-cases-in-the-world-who>.